



PIETRELLI
porte

PIETRELLI
porte

La passione e la volontà di dar vita a soluzioni uniche, la capacità di interpretare le esigenze di clienti e progettisti, la certezza di impiegare materiali e sistemi di qualità per elevare il livello complessivo del sistema porta: F.lli Pietrelli parte da questi capisaldi, da una tradizione artigianale che nel corso degli anni si è trasformata in produzione industriale mantenendo nel proprio dna, l'attenzione al dettaglio, al su misura.... insomma al progetto. Nascono così le porte per interni destinate all'ambito residenziale o al settore contract, soluzioni dall'estetica essenziale o più elaborata, personalizzabili per finitura, design, colore, o tipologia di apertura. Porte che definiscono spazi, impreziosiscono pareti, contribuiscono alla lettura di ogni architettura nella quale sono inserite, porte progettate e realizzate per il cliente e non per il mercato.

The passion and the desire to create customized solutions, the ability to understand the exigence of customers and designers, the security of using materials and quality systems to increase the overall level of the system leads Pietrelli as an artisan tradition that over the years has become industrial production, keeping its attention to detail, tailor-made... in short, to the project. Thus, interior doors are designed for hotel, residential and contract market, solutions that are essential or more elaborate, customized in finishes, design and color. Doors that define spaces, revalue walls, contribute to connect with the architecture in which they are installed, doors designed and realized for the customer and not for the market.

La passion et le désir de créer des solutions uniques, la capacité d'interpréter les besoins des clients et des concepteurs, la certitude d'employer des matériaux et des systèmes de qualité pour élever le niveau global du système conduit la Pietrelli vers une tradition artisanale qui est devenue une production industrielle, en attirant l'attention sur les détails en détail, sur mesure... en bref, sur le projet. Ainsi, les portes intérieures sont conçues pour le secteur résidentiel ou contract, des solutions essentielles ou plus élaborées, sur mesure en finition, conception, couleur et type d'ouverture. Les portes qui définissent des espaces, embellissent des murs, contribuent à la lecture de toute l'architecture dans laquelle elles sont insérés, des portes conçues et réalisées pour le client et non pour le marché.

Страсть и желание создавать уникальные решения, способность раскрывать замыслы клиентов и дизайнеров, надежность используемых материалов и контроль качества, направленный на повышение общего уровня системы - с этих основополагающих моментов начинается фабрика F.lli Pietrelli, которая на протяжении лет прошла путь от традиционной ремесленной мастерской до промышленного предприятия, сохранив свою ДНК, внимание к каждой детали, пожеланиям клиента... иными словами, к проекту. Так рождаются межкомнатные двери для жилого или контрактного сектора, сложные эстетические решения, отмеченные индивидуальностью в своих отделках, цветах, дизайне, типологии открывания. Двери характеризуют пространство, украшают стены, вносят вклад в прочтение архитектурного объема, в который они вовлечены, эти двери спроектированы и выполнены для клиента, а не для рынка.

MIMESI

La volontà aziendale di ricercare la massima competitività e flessibilità produttiva ha portato allo sviluppo della Linea Mimesi, caratterizzata da porte in linea con le tendenze contemporanee, disponibili in versione battente tradizionale, scorrevole, a filo muro e centro muro senza telaio e coprifili, per conferire un'estrema leggerezza e pulizia formale. La porta non è più un semplice complemento, ma diventa così un autentico elemento d'arredo.

Company's focus, oriented to seek the best competitiveness and flexibility in production, allowed the development of Mimesi Collection, characterized with doors featured by contemporary trends. These doors are available in a traditional swing opening, sliding, wall edge and wall centered without frame and architraves, and confer extreme lightness with a pleasant aesthetic view. The door considered as a no longer a simple item, but a proper piece of furniture.

L'engagement constant à la poursuite de la compétitivité maximale et de la flexibilité productive a conduit au développement de la Collection Mimesi, caractérisée par des portes conformes aux tendances contemporaines, disponibles en version traditionnelle, coulissante, au ras du mur sans cadre et couvre joints, pour conférer extrême légèreté et nettoyage formel. La porte n'est plus un simple complément, mais devient un élément d'ameublement.

Стремление компании к максимальной конкурентоспособности и гибкости производства привело к развитию Linea Mimesi. Ее характеризуют двери, соответствующие современным тенденциям, доступные в версиях: традиционные распашные, откатные, filo muro (в уровень стены) и в центр стены без коробки и наличников, чем достигается максимальная легкость и чистота форм. Дверь уже не является простым компонентом, но превращается в подлинный элемент интерьера.

MIMESI DEMETRA

Laccato moka lucido
Telaio Demetra

Glossy moka lacquered
Frame Demetra

Laqué moka brillant
Cadre Demetra

Блестящая окраска мoka
коробка Demetra



MIMESI DEMETRA

Laccato bianco Pietrelli lucido
Telaio Demetra

Glossy white Pietrelli lacquered
Frame Demetra

Laqué blanc Pietrelli brillant
Cadre Demetra

Блестящая окраска белый Pietrelli
коробка Demetra



MIMESI DEMETRA

Scorrevole interno muro
Laccato RAL 3005 lucido

Internal sliding
Glossy RAL 3005 lacquered

Coulissante à l'intérieur de la cloison
Laquée RAL 3005 brillant

Дверь откатная в стену
блестящая окраска RAL 3005



MIMESI DEMETRA

Laccato RAL 7038 lucido
Telaio Demetra

Glossy RAL 7038 lacquered
Frame Demetra

Laqué RAL 7038 brillant
Cadre Demetra

Блестящая окраска RAL 7038
Коробка Demetra



MIMESI DEMETRA

Laccato bianco Pietrelli
Telaio Demetra

White Pietrelli lacquered
Frame Demetra

Laqué blanc Pietrelli
Cadre Demetra

Блестящая окраска белый Pietrelli
Коробка Demetra



MIMESI DEMETRA

Laccato panna Pietrelli
Telaio Demetra

Cream Pietrelli lacquered
Frame Demetra

Laqué crème Pietrelli
Cadre Demetra

Блестящая окраска сливочный
Pietrelli
Коробка Demetra



MIMESI DEMETRA

Poro aperto laccato savana
Telaio Demetra (à tirare)

Open pore savanna lacquered
Frame Demetra (pull side)

Pore ouvert laqué savane
Cadre Demetra (à tirer)

Окраска savana с видимой
структурой дерева
Коробка Demetra
(открывание на себя)



MIMESI DEMETRA

Millerighe brown
Telaio Demetra

Millerighe brown
Frame Demetra

Millerighe brown
Cadre Demetra

Millerighe коричневый
Коробка Demetra



MIMESI DEMETRA

A sinistra: scorrevole vetro laccato
bianco Pietrelli
A destra: laccato bianco Pietrelli
Telaio Demetra

On the left: internal sliding glass door
white Pietrelli
On the right: white Pietrelli lacquered
Frame Demetra

A gauche: coulissante laquée blanc
Pietrelli
A droite: laqué blanc Pietrelli
Cadre Demetra

Слева: откатная стеклянная дверь
белый Pietrelli.
Справа: блестящая окраска белый
Pietrelli Коробка Demetra



MIMESI DEMETRA

A vetro laccato bianco Pietrelli
(a tirare)
Telaio Demetra

Glass door white Pietrelli lacquered
(pull side)
Frame Demetra

Vitrée laqué blanc Pietrelli (à tirer)
Cadre Demetra

Дверь стеклянная белый Pietrelli
(открывание на себя)
Коробка Demetra



MIMESI DEMETRA

Cabina armadio laccato bianco Pietrelli

Walk-in wardrobe white Pietrelli
lacquered

Placard laqué blanc Pietrelli

Шкаф-купе окраска белый Pietrelli

**MIMESI
PANACEA**

Laccato a campione

Lacquered customized colour

Laqué au choix

Окраска по образцу



**MIMESI
PANACEA**

Laccato RAL 9005 nero lucido

Polished lacquered RAL 9005

Laqué brillant RAL 9005

Окраска RAL 9005 черный блестящий



MIMESI AFRODITE

Laccato RAL 7022 lucido
Telaio Afrodite RAL 7022 texturizzato

Glossy RAL 7022 lacquered
Frame Afrodite anti-scratch RAL 7022
lacquered

Laqué RAL 7022 brillant
Cadre Afrodite RAL 7022 anti-rayure

Блестящая окраска RAL 7022
Коробка Afrodite матовый RAL 7022



Capitello esterno

Exterior capital

Charpente exterieur

Внешняя капитель



MIMESI ERMES

A sinistra:
laccato RAL 7002
Telaio Compact
laccato RAL 7006 texturizzato
A destra:
versione a vetro

On the left:
RAL 7002 lacquered
Frame Compact anti-scratch
RAL 7006 lacquered
On the right:
glass door

A gauche:
laqué RAL 7002
Cadre Compact
laqué RAL 7006 anti-rayure
A droite:
version vitrée

Слева:
окраска RAL 7002
Коробка Compact
окраска RAL 7006 матовая.
Справа:
вариант со стеклом



MIMESI ARTEMIDE

Laccato RAL 7022
Telaio Compact
laccato RAL 7022
texturizzato

Matt RAL 7022 lacquered
Frame Compact anti-scratch
RAL 7022 lacquered

Laqué RAL 7022
Cadre Compact laqué
RAL 7022 anti-rayure

Окраска RAL 7022
Коробка Compact
матовая окраска
RAL 7022

MIMESI ARTEMIDE

Millerighe white
Telaio Compact
laccato RAL 9010 texturizzato

Millerighe white
Frame Compact
anti-scratch RAL 9010 lacquered

Millerighe blanc
Cadre Compact
laqué RAL 9010 anti-rayure

Millerighe белый
Корока Compact
матовая окраска RAL 9010

MIMESI ARTEMIDE

Millerighe brown
(vista a tirare)
Telaio Compact
laccato savana texturizzato

Millerighe brown (pull side)
Frame Compact
anti-scratch savanna lacquered

Millerighe brown (à tirer)
Cadre Compact
laqué savane anti-rayure

Millerighe коричневый
(вид со стороны открывания на себя)
Коробка Compact
матовая окраска savana

MIMESI ARTEMIDE

Laccato bianco Pietrelli lucido
Telaio Compact laccato bianco Pietrelli
texturizzato

Glossy white Pietrelli lacquered
Frame Compact anti-scratch white
Pietrelli lacquered

Laqué blanc Pietrelli brillant
Cadre Compact laqué blanc Pietrelli
anti-rayure

Блестящая окраска белый Pietrelli
Коробка Compact матовая окраска
белый Pietrelli

MIMESI MINERVA

Laccato bianco Pietrelli
Telaio Quadrus laccato bianco Pietrelli
texturizzato

White Pietrelli lacquered
Frame Quadrus anti-scratch white
Pietrelli lacquered

Laqué blanc Pietrelli
Cadre Quadrus laqué blanc Pietrelli
anti-rayure

Окраска белый Pietrelli Коробка
Quadrus
матовая окраска
белый Pietrelli



MIMESI MINERVA

Laccato bianco Pietrelli Lucido (a tirare)
Telaio Quadrus laccato bianco Pietrelli texturizzato

Glossy white Pietrelli lacquered (pull side)
Frame Quadrus anti-scratch white Pietrelli lacquered

Laqué blanc Pietrelli brillant (à tirer)
Cadre Quadrus laqué blanc Pietrelli anti-rayure

Блестящая окраска белый Pietrelli (открывание на себя)
Коробка Quadrus матовая окраска белый Pietrelli



MIMESI MINERVA

A vetro Laccato bianco Pietrelli
Telaio Quadrus laccato bianco Pietrelli texturizzato

Glass door white Pietrelli lacquered
Frame Quadrus anti-scratch white Pietrelli lacquered

Vitrée laqué blanc Pietrelli
Cadre Quadrus laqué blanc Pietrelli anti-rayure

Окрашенное стекло белый Pietrelli
Коробка Quadrus матовая окраска белый Pietrelli

MIMESI MINERVA

Rovere cognac
Telaio Rovere cognac

Cognac Oak
Frame Cognac Oak

Chêne cognac
Cadre Chêne cognac

Дуб Коньяк
Коробка Дуб Коньяк



MIMESI
MINERVA

Rovere grigio
Telaio Rovere grigio

Gray oak
Frame gray Oak

Chêne gris
Cadre Chêne gris

Серый Дуб
Коробка Серый Дуб



MIMESI KRONOS

Termostrutturato rovere sabbia
Thermostructured sand oak
Termostreuré gris sable
Термоструктура песочный дуб



MIMESI KRONOS

Termostrutturato rovere grigio
Thermostructured gray oak
Termostreuré chêne gris
Термоструктура серый дуб





**MIMESI
KRONOS**

Termostrutturato
rovere bianco poro aperto

Thermostructured
white oak open pore

Termostructuré chêne
blanc pore ouvert

Термоструктура
белый дуб с открытой порой

rovere bianco poro aperto
white oak open pore
chêne blanc pore ouvert
белый дуб с открытой порой

**MIMESI
DIANA**

Palude oak
Telaio Compact laccato RAL 7022
texturizzato

Palude oak
Frame Compact anti-scratch RAL 7022
lacquered

Palude oak
Cadre Compact laqué RAL 7022
anti-rayure

Palude oak
Коробка Compact матовая окраска
RAL 7022

MIMESI DIANA

Silver
Telaio Compact laccato bianco
Pietrelli texturizzato

Silver
Frame Compact anti-scratch white
Pietrelli lacquered

Silver
Cadre Compact laqué blanc Pietrelli
anti-rayure

Silver
Коробка Compact матовая окраска
белый Pietrelli



Battiscopa minimale
altezza cm.4 con angolari

Minimal baseboard (h.4 cm)
with metal corner beads

Plinthe minimal h.4 cm avec angulaires

Плинтус минимальная высота 4 см,
с уголками

MIMESI DIANA

Dark lady
Telaio Compact laccato
RAL 7022 texturizzato

Dark lady
Frame Compact anti-scratch
RAL 7022 lacquered

Dark lady
Cadre Compact laqué
RAL 7022 anti-rayure

Dark lady
Коробка Compact матовая
окраска RAL 7022



MIMESI ADE

Laccato bianco Pietrelli
Telaio Compact laccato bianco Pietrelli
texturizzato

White Pietrelli lacquered
Frame Compact anti-scratch white
Pietrelli lacquered

Laqué blanc Pietrelli
Cadre Compact laqué blanc Pietrelli
anti-rayure

Окраска белый Pietrelli
Коробка Compact матовая окраска
белый Pietrelli



MIMESI MEDUSA

Laccato savana lucido
Telaio Compact laccato savana
texturizzato

Glossy savanna lacquered
Frame Compact anti-scratch savanna
lacquered

Laqué savane brillant
Cadre Compact laqué savane anti-rayure

Блестящая окраска savana Коробка
Смрпак матовая окраска savana





MIMESI ERA

A sinistra:
versione a vetro
laccato bianco Pietrelli
Telaio Compact
laccato bianco Pietrelli
texturizzato
A destra:
versione a battente cieca

On the left:
glass door white
Pietrelli lacquered
Frame Compact
anti-scratch white
Pietrelli lacquered
On the right:
full hinged door

A gauche:
vitrée laqué blanc Pietrelli Cadre
Compact laqué blanc Pietrelli
anti-rayure
A droite:
version à battant

Слева:
вариант с окрашенным стеклом
белый Pietrelli
Коробка Compact матовая окраска
белый Pietrelli.
Справа:
распашная глухая дверь

MIMESI ODISSEA

A sinistra:
versione a vetro
laccato bianco Pietrelli
Telaio Compact
laccato bianco Pietrelli
texturizzato

A destra:
versione a battente cieca
(a tirare)

On the left:
Glass door white
Pietrelli lacquered
Frame Compact
anti-scratch white
Pietrelli lacquered

On the right:
full hinged door
(pull side)

A gauche:
vitrée laqué blanc Pietrelli
Cadre Compact laqué blanc Pietrelli
anti-rayure

A droite:
version à battant (à tirer)

Слева:
вариант с окрашенным стеклом
белый Pietrelli
Коробка Compact матовая окраска
белый Pietrelli

Справа:
распашная глухая дверь
(открывание на себя)



MIMESI AURORA

Laccato RAL 9001
Telaio Compact RAL 9001

Lacquered RAL 9001
Frame Compact RAL 9001

Laqué RAL 9001
Cadre Compact RAL 9001

Окраска RAL 9001
Коробка Compact RAL 9001



MIMESI DIANA

A vetro - Laccato Bianco Pietrelli
Telaio Compact Bianco Pietrelli

Glass - Lacquered White Pietrelli
Frame Compact White Pietrelli

Vitré - Laqué Blanc Pietrelli
Cadre Compact Blanc Pietrelli

Со стеклом - Окраска Белый Pietrelli
Коробка Компакт Белый Pietrelli





MIMESI
DAFNE

Laccato RAL 9002
Telaio Compact RAL 9002

Lacquered RAL 9002
Frame Compact RAL 9002

Laqué RAL 9002
Cadre Compact RAL 9002

Окраска RAL 9002
Коробка Compact RAL 9002



**MIMESI
VULCANO**

Laccato RAL 1013
Telaio Compact RAL 1013

Lacquered RAL 1013
Frame Compact RAL 1013

Laqué RAL 1013
Cadre Compact RAL 1013

Окраска RAL 1013
Коробка Compact RAL 1013



MIMESI ERA

Laccato a campione
Telaio rototraslante

Customized lacquered
Frame rototranslation

Lacqué sur demande
Cadre model rototranslation

Окраска по образцу
Коробка с роторным механизмом



**MIMESI
SATURNO**

Rovere cognac
Telaio Rovere cognac

Cognac Oak
Frame Cognac Oak

Chêne cognac
Cadre Chêne cognac

Дуб Коньяк
Коробка Дуб Коньяк



**MIMESI
BACCO**

Rovere naturale
Telaio Rovere naturale

Natural Oak
Frame Natural Oak

Chêne naturel
Cadre Chêne naturel

Натуральный Дуб
Коробка Дуб Коньяк

MIMESI RASOMURO

Laccato RAL 9010
Telaio Rasomuro RAL9010
(versione Rasomuro 1 e Rasomuro 2)

Lacquered RAL 9010
Frame Rasomuro RAL 9010
(available Rasomuro 1 and Rasomuro 2)

Laqué RAL 9010
Cadre Rasomuro RAL 9010
(disponible Rasomuro 1 e Rasomuro 2)

Окраска RAL 9010
Коробка Rasomuro RAL 9010
(доступный Rasomuro 1 e Rasomuro 2)



MIMESI ETNA

Laccato RAL 7038
Telaio Etna RAL 7038

Lacquered RAL 7038
Frame Etna Lacquered RAL 7038

Lacqué RAL 7038
Cadre Etna Lacqué RAL 7038

Окраска RAL 7038
Коробка Etna RAL 7038



MIMESI
ARMONIA

Laccato RAL 9010
Telaio Armonia Ral 9010

Lacquered RAL 9010
Frame Armonia Lacquered Ral 9010

Lacqué RAL 9010
Cadre Armonia Lacqué RAL 9010

Окраска RAL 9010
Коробка Armonia RAL 9010



Dettaglio telaio

Frame detail

Detail du cadre

Деталь коробки

MIMESI BACCO

Laccato RAL 9010
Telaio Compact RAL 9010

Lacquered RAL 9010
Frame Compact RAL 9010

Laqué RAL 9010
Cadre Compact RAL 9010

Окраска RAL 9010
Коробка Compact RAL 9010



MIMESI TECNOALL

Vetro - Arta alluminio/vetro
Telaio alluminio satinato

Glass - Leaf aluminium/glass
Frame matt aluminium

Vitré - Vantail aluminium/Vitré
Cadre aluminium opaque

Стекло - Створка алюминий / стекло
Коробка сатинированный алюминий



MIMESI SYMPOSIUM

Alluminio/vetro

Aluminium/glass

Aluminium/vitré

Алюминий / стекло





**MIMESI
ICARO**

Scorrevole esterno muro
laccato a campione

External sliding
lacquered customized colour

Couissante en applique
laqué au choix

Дверь откатная по стене
окраска по образцу



**MIMESI
VENUS**

A vetro scorrevole esterno muro
laccato RAL 4008

Glass door external sliding
RAL 4008 lacquered

Vitrée coulissante en applique
laqué RAL 4008

Дверь откатная по стене
окраска RAL 4008

MIMESI VENUS

A vetro Scorrevole
esterno muro
laccato RAL 8017

Glass door external
sliding RAL 8017
lacquered

Vitrée coulissante
en applique laqué RAL 8017

Стеклопанельная дверь
откатная по стене окраска RAL 8017



MIMESI EGEMONE

Laccato a campione

Lacquered customized colour

Laqué au choix

Окраска по образцу



GENESI

La Pietrelli Porte da sempre ha l'obiettivo di fornire porte di altissimo pregio. La Linea Genesi con porte classiche si distingue sul mercato per eccellenza, funzionalità e bellezza, risultato di oltre 50 anni di passione, esperienza e maestria artigiana per un prodotto che si ispira al passato, presente e futuro.

Pietrelli Porte has always provided high quality doors. Genesi Collection with classic doors is characterized for excellence, functionality and loveliness, a result of over 50 years of passion, experience and handcraft for a product inspired by the past, during the present and oriented to the future.

Pietrelli Porte a toujours visé à fournir des portes de haute qualité. La Collection Genesi avec des portes classiques se distingue sur le marché pour excellence, fonctionnalité et beauté, résultat de plus de 50 ans de passion, d'expérience et d'artisanat pour un produit inspiré du passé, au présent, avec un regard sur l'avenir.

Pietrelli Porte всегда имела целью поставлять двери самого высокого качества. Linea Genesis со своими классическими дверями выделяется на рынке исключительностью, функциональностью и красотой. Это результат более чем 50-летней страсти, опыта и ремесленного мастерства, направленного на создание продукта, который вдохновлен прошлым, настоящим и будущим.

**GENESI
CLARA**

Laccato panna Pietrelli opaco
Telaio TC raggio 2

Matt lacquered, Pietrelli cream
Frame TC radius 2

Laquée crème Pietrelli opaque
Cadre TC rayon 2

Матовая окраска крем кость Pietrelli
Коробка TC радиус 2





GENESI NELLA

Laccato bianco Pietrelli opaco
Telaio TC raggio 2

Matt lacquered, Pietrelli white
Frame TC radius 2

Laquée blanc Pietrelli opaque
Cadre TC rayon 2

Матовая окраска белый Pietrelli
Коробка TC радиус 2

GENESI TANIA

Laccato bianco Pietrelli opaco
Telaio TC raggio 2

Matt lacquered, Pietrelli white
Frame TC radius 2

Laquée blanc Pietrelli opaque
Cadre TC rayon 2

Матовая окраска белый Pietrelli
Коробка ТС радиус 2



GENESI SONIA

Laccato bianco Pietrelli opaco
Telaio TC raggio 2

Matt lacquered, Pietrelli white
Frame TC radius 2

Laquée blanc Pietrelli opaque
Cadre TC rayon 2

Матовая окраска белый Pietrelli
Коробка ТС радиус 2



GENESI CLARA

Vetro intero
laccato bianco Pietrelli opaco
Telaio TC raggio 2

Full glass
matt lacquered, Pietrelli white
Frame TC radius 2

Vitrée
laquée blanc Pietrelli opaque
Cadre TC rayon 2

Дверь со стеклом
Матовая окраска белый Pietrelli
Коробка TC радиус 2



GENESI SISSI

Laccato panna Pietrelli 671
Telaio TC raggio 2

Lacquered, Pietrelli cream 671
Frame TC radius 2

Laquée crème Pietrelli 671
Cadre TC rayon 2

Матовая окраска сливочный
Pietrelli 671
Коробка TC радиус 2





GENESI VALENTINA

Vetro intero
laccato bianco Pietrelli opaco
Telaio TC raggio 2

Full glass
matt lacquered, Pietrelli white
Frame TC radius 2

Vitrée
laquée blanc Pietrelli opaque
Cadre TC rayon 2

Дверь с длинным стеклом
Матовая окраска белый Pietrelli
Коробка TC радиус 2

GENESI VALENTINA

Laccato bianco Pietrelli opaco
Telaio TC raggio 2

Matt lacquered, Pietrelli white
Frame TC radius 2

Laquée blanc Pietrelli opaque
Cadre TC rayon 2

Матовая окраска белый
Коробка TC радиус 2



GENESI MADRID

Laccato bianco Pietrelli opaco
Telaio Scalare

Matt lacquered, Pietrelli white
Frame Scalare

Laquée blanc Pietrelli opaque
Cadre Scalare

Матовая окраска белый Pietrelli
Коробка Scalare



GENESI LISBONA

Vetro / scorrevole
laccato bianco Pietrelli opaco
Telaio TC raggio 2

Full glass / internal sliding
matt lacquered, Pietrelli white
Frame TC radius 2

Vitrée / Coulissante
laquée blanc Pietrelli opaque
Cadre TC rayon 2

Дверь с внутренним стеклом / Дверь,
откатная в стену
Матовая окраска белый Pietrelli
Коробка TC радиус 2



GENESI LONDRA

Laccato bianco Pietrelli opaco
Telaio TC raggio 2

Matt lacquered, Pietrelli white
Frame TC radius 2

Laquée blanc Pietrelli opaque
Cadre TC rayon 2

Матовая окраска белый Pietrelli
Коробка ТС радиус 2



GENESI ATENE

Cieca / Vetro
impiallacciato noce tanganica tinto
ciliegio

Plain / Full glass
veneered,
walnut tanganika cherry dyed

Pleine / Vitrée
placage noyer tanganika teinte
cerisier

Глухая дверь / Дверь с раздельными
стеклами
Шпон танганйского ореха,
тонированного под вишню



GENESI VIENNA

Cieca / Vetro intero
impiallacciato noce tanganica tinto
ciliegio

Plain / Full glass
veneered, walnut tanganika cherry
dyed

Pleine / Vitrée
placage noyer tanganika
teinte cerisier

Глухая дверь / Дверь с длинным
стеклом
Шпон танганйского ореха,
тонированного под вишню





**GENESI
DUCALE
1BR REVERS**

Impiallacciato noce nazionale bicolore
Telaio TC raggio 2

Veneered, national two-coloured walnut
Frame TC radius 2

Placage noyer national bicolore
Cadre TC rayon 2

Шпон двухцветного национального
ореха
Коробка TC радиус 2



**GENESI
DUCALE
2 BR REVERS**

Laccato panna Pietrelli 671 Telaio
Fregio '500

Lacquered, Pietrelli cream 671
Frame Fregio '500

Laquée crème Pietrelli 671
Cadre Fregio '500

Матовая окраска сливочный
Pietrelli 671
Коробка Fregio '500

GENESI
**DUCALE
2 BR CLASSIC**

Impiallacciato noce nazionale bicolore
Telaio TC raggio 2

Veneered, national two-coloured walnut
Frame TC radius 2

Placage noyer national bicolore
Cadre TC rayon 2

Шпон двухцветного национального ореха
Коробка TC радиус 2



GENESI
**DUCALE
3 BR REVERS**

Laccato verde Pietrelli anticato

Old-looking lacquered, Pietrelli green

Laquée vert Pietrelli antique

Окраска зеленый Pietrelli состаренный



**GENESI
DUCALE
4 BR REVERS**

Laccato avorio Pietrelli 242
Telaio Composto Classico

Lacquered, Pietrelli ivory 242
Frame Composto Classico

Laquée Ivoire Pietrelli 242
Cadre Composto classique

Матовая окраска слоновая кость
Pietrelli 242
Коробка Composto Classico



**GENESI
SISSI
PIEGHEVOLE 1/3**

Pieghevole 1/3
laccato bianco Pietrelli opaco
Telaio TC raggio 2

Folding 1/3
matt lacquered, Pietrelli white
Frame TC radius 2

Pliante 1/3
laquée blanc Pietrelli opaque
Cadre TC rayon 2

Складная дверь 1/3
Матовая окраска белый Pietrelli
Коробка TC радиус 2



GENESI
TECNO 2 BSD

Impiallacciato noce nazionale bicolore
Telaio TC raggio 2

Veneered, national two-coloured walnut
Frame TC radius 2

Placage noyer national bicolore
Cadre TC rayon 2

Шпон двухцветного национального
ореха
Коробка TC радиус 2



GENESI
TECNO 2 BS

Impiallacciato noce tanganica tinto medio
Telaio TC raggio 2

Veneered, medium tanganika walnut
Frame TC radius 2

Placage noyer tanganika teinte moyen
Cadre TC rayon 2

Шпон танганйского ореха,
среднетонированный
Коробка TC радиус 2



GENESI LM

Laccato bianco Pietrelli opaco
Telaio TC raggio 2

Matt lacquered, Pietrelli white
Frame TC radius 2

Laquée blanc Pietrelli opaque
Cadre TC rayon 2

Матовая окраска белый Pietrelli
Коробка TC радиус 2



GENESI LM

Laccato bianco Pietrelli opaco
con inserto in alluminio opaco
Telaio TC raggio 2

Matt lacquered, Pietrelli white
with matt aluminium stripe
Frame TC radius-2

Laquée blanc Pietrelli opaque
avec insert en aluminium opaque
Cadre TC rayon 2

Матовая окраска белый Pietrelli
дверь с алюминией
Коробка TC радиус 2



GENESI LMVP

Vetro piombi
Laccato bianco Pietrelli opaco
Telaio TC raggio 2

Small glasses
matt lacquered, Pietrelli white
Frame TC radius 2

Vitrée
laquée blanc Pietrelli opaque
Cadre TC rayon 2

Дверь с раздельными стеклами
Матовая окраска белый Pietrelli
Коробка TC радиус 2

GENESI INGLESE

Vetro piombi
Impiallacciato noce tanganica tinto medio
Telaio TC raggio 2

Small glasses
veneered, medium tanganika walnut
Frame TC radius 2

Vitrée
placage noyer tanganika teinte moyen
Cadre TC rayon 2

Дверь с раздельными стеклами
Шпон танганийского ореха,
среднетонированный
Коробка TC радиус 2



GENESI LM INCISO

Laccato bianco Pietrelli opaco
Telaio TC raggio 2

Matt lacquered, Pietrelli white
Frame TC radius 2

Laquée blanc Pietrelli opaque
Cadre TC rayon 2

Матовая окраска белый Pietrelli
Коробка ТС радиус 2



GENESI LM

Impiallacciato rovere naturale
Telaio TC raggio 2

Veneered, natural oak
Frame TC radius 2

Placage chêne naturel
Cadre TC rayon 2

Шпон натурального дуба
Коробка ТС радиус 2

GENESI LM

Impiallacciato noce tanganica tinto medio
Telaio TC raggio 2

Veneered, medium tanganika walnut
Frame TC radius 2

Placage noyer tanganika teinte moyen
Cadre TC rayon 2

Шпон танганйского ореха,
среднетонированный
Коробка ТС радиус 2

GENESI LMV

Vetro intero
impiallacciato noce tanganica tinto medio
Telaio TC raggio 2

Full glass
veneered, medium tanganika walnut
Frame TC radius 2

Vitrée
placage noyer tanganika teinte moyen
Cadre TC rayon 2

Дверь с длинным стеклом Шпон
танганйского ореха, среднетонированный
Коробка ТС радиус 2



GENESI LMO

Impiallacciato noce
tanganica naturale
Telaio TC raggio 2

Veneered, natural
tanganika walnut
Frame TC radius-2

Placage noyer
tanganika naturel
Cadre TC rayon 2

Шпон натурального
танганйского ореха
Коробка TC радиус 2



GENESI PARIGI

Vetro
Laccato Bianco Pietrelli
Telaio Raggio 2 Laccato bianco Pietrelli

Glass
Lacquered white Pietrelli
Frame Radius 2 lacquered white Pietrelli

Vitré
Laqué blanc Pietrelli
Cadre rayon 2 laqué blanc Pietrelli

Стекло
Окраска Белый Pietrelli
Коробка Raggio 2 Окраска Белый Pietrelli



GENESI PARIGI

Laccato Bianco Pietrelli
Telaio Raggio 2 Laccato bianco Pietrelli

Lacquered white Pietrelli
Frame Radius 2 lacquered white Pietrelli

Laqué blanc Pietrelli
Cadre rayon 2 laqué blanc Pietrelli

Окраска Белый Pietrelli
Коробка Raggio 2 Окраска Белый Pietrelli



GENESI PARIGI

Scorrevole
Laccato a campione
Telaio scorrevole laccato a campione

Sliding
Customized lacquered
Sliding frame customized lacquered

Couissante
Laqué sur mesure
Cadre coulissante laqué sur demande

Откатная
Окраска по образцу
Коробка для откатной двери Окраска
по образцу





GENESI PARIGI

Scorrevole esterna
laccato bianco Pietrelli opaco
Telaio TC raggio 2

Sliding external
matt lacquered, Pietrelli white
Frame TC radius 2

Couissant extérieur
laquée blanc Pietrelli opaque
Cadre TC rayon 2

Дверь, открывающаяся по стене
Матовая окраска белый Pietrelli
Коробка TC радиус 12



GENESI
LMA

Laminato rovere sbiancato
Telaio raggio 2

Laminate bleached oak
Frame radius-2

Laminé chêne blanc
Cadre rayon 2

Ламинат беленый дуб
Коробка радиус 2



GENESI
LMA

Laminato wengè
Telaio raggio 2

Laminate wengè
Frame radius-2

Laminé wengè
Cadre rayon 2

Ламинат венге
Коробка радиус 2



Luce passaggio Light opening Mesure de passage Чистый пролет по проходу	Misura esterno controtelaio External sub-frame Encombrement du precadre По внешней части накладной коробки	Vano utile grezzo Wall opening Passage utile Полезный проем
X (700-750-800)	A=X+130mm	B=X+150mm
Y (2100-2400)	C=Y+65mm	D=Y+90mm

DEMETRA
Telaio / Frame / Cadre / Коробка

Quota pavimento finito
Finished floor surface
Sol fini
Конечный пол

DEMETRA
Telaio / Frame / Cadre / Коробка

Luce passaggio Light opening Mesure de passage Чистый пролет по проходу	Misura esterno telaio External frame Encombrement du cadre По внешней части коробки	Vano utile - Misura Interno Controtelaio Wall opening or Internal sub-frame Passage utile-Intérieur du precadre Полезный проем-По внутренней части накладной коробки
X	A=X+80mm	B=X+100mm
Y	C=Y+40mm	D=Y+50mm

MINERVA

Quota pavimento finito
Finished floor surface
Sol fini
Конечный пол

QUADRUS
Telaio / Frame / Cadre / Коробка

Rapporto per telaio Quadrus
Frame extensio, frame Quadrus
Rapport pour cadre Quadrus
доборная планка для коробки Quadrus

Luce passaggio Light opening Mesure de passage Чистый пролет по проходу	Misura esterno controtelaio External sub-frame Encombrement du precadre По внешней части накладной коробки
X	B=2X+130mm
Y	D=Y+80mm

DEMETRA
Scorrevole interno muro
Internal sliding
Porte coulissante à l'intérieur de la cloison
Дверь, откатная в стену

Quota pavimento finito
Finished floor surface
Sol fini
Конечный пол

DEMETRA
Scorrevole interno muro
Internal sliding
Porte coulissante à l'intérieur de la cloison
Дверь, откатная в стену

Luce passaggio Light opening Mesure de passage Чистый пролет по проходу	Misura esterno telaio External frame Encombrement du cadre По внешней части коробки	Vano utile - Misura Interno Controtelaio Wall opening or Internal sub-frame Passage utile-Intérieur du precadre Полезный проем-По внутренней части накладной коробки
X	A=X+80mm	B=X+100mm
Y	C=Y+40mm	D=Y+50mm

ADE-ARTEMIDE-DIANA-ERA-ERMES-MEDUSA-ODISSEA

Quota pavimento finito
Finished floor surface
Sol fini
Конечный пол

COMPACT
Telaio / Frame / Cadre / Коробка

Rapporto per telaio Compact
Frame extensio, frame Compact
Rapport pour cadre Compact
доборная планка для коробки Compact

Luce passaggio Light opening Mesure de passage Чистый пролет по проходу	Misura esterno telaio External frame Encombrement du cadre По внешней части коробки	Vano utile - Misura Interno Controtelaio Wall opening or Internal sub-frame Passage utile-Intérieur du precadre Полезный проем-По внутренней части накладной коробки
X	A=X+130mm	B=X+140mm
Y	C=Y+13mm	D=Y+16mm

PANACEA

Quota pavimento finito
Finished floor surface
Sol fini
Конечный пол

PANACEA
Telaio / Frame / Cadre / Коробка

PANACEA
Telaio / Frame / Cadre / Коробка

Luce passaggio Light opening Mesure de passage Чистый пролет по проходу	Misura esterno telaio External frame Encombrement du cadre По внешней части коробки	Vano utile - Misura Interno Controtelaio Wall opening or Internal sub-frame Passage utile-Intérieur du precadre Полезный проем-По внутренней части накладной коробки
X	A=X+130mm	B=X+130mm
Y	C=Y+65mm	D=Y+65mm

ARMONIA

Quota pavimento finito
Finished floor surface
Sol fini
Конечный пол

ELEGANCE
Telaio / Frame / Cadre / Коробка

Luce passaggio Light opening Mesure de passage Чистый просвет по проходу	Interno Controtelaio Internal sub-frame Intérieur du precadre По внутренней части накладной коробки	Vano utile - Misura interno Controtelaio Wall opening or Internal sub-frame Passage utile-Intérieur du precadre Полезный проем-По внутренней части накладной коробки
X	B=X+40mm	C=2X+80mm
Y	D=Y+50mm	E=Y+90mm

ADE-ARMONIA-ARTEMIDE-DIANA-ERA
ERMES-ETNA-MEDUSA-MINERVA-ODISSEA
Scorrevole interno muro
Internal sliding
Porte coulissante à l'intérieur de la cloison
Дверь, откатная в стену

Quota pavimento finito
Finished floor surface
Sol fini
Ковенный пол

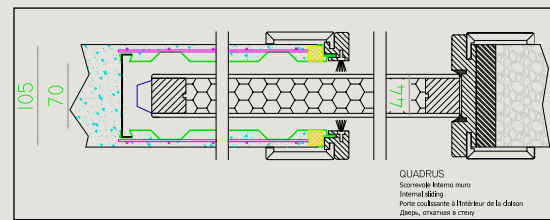

Luce passaggio Light opening Mesure de passage Чистый просвет по проходу	Misura esterno telaio External frame Encombrement du cadre По внешней части коробки	Vano utile - Misura interno Controtelaio Wall opening or Internal sub-frame Passage utile-Intérieur du precadre Полезный проем-По внутренней части накладной коробки
X	A=X+80mm	B=X+100mm
Y	C=Y+40mm	D=Y+50mm

AFRODITE

Quota pavimento finito
Finished floor surface
Sol fini
Ковенный пол

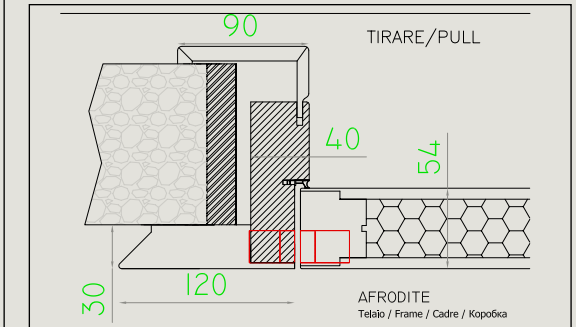
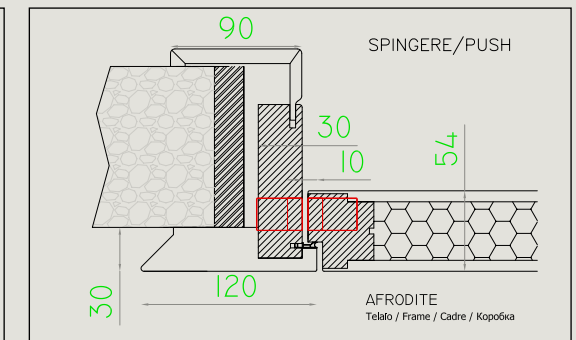

Luce passaggio Light opening Mesure de passage Чистый просвет по проходу	Misura esterno telaio External frame Encombrement du cadre По внешней части коробки	Vano utile - Misura interno Controtelaio Wall opening or Internal sub-frame Passage utile-Intérieur du precadre Полезный проем-По внутренней части накладной коробки
X	A=X+80mm	B=X+100mm
Y	C=Y+40mm	D=Y+50mm

ETNA

Quota pavimento finito
Finished floor surface
Sol fini
Ковенный пол

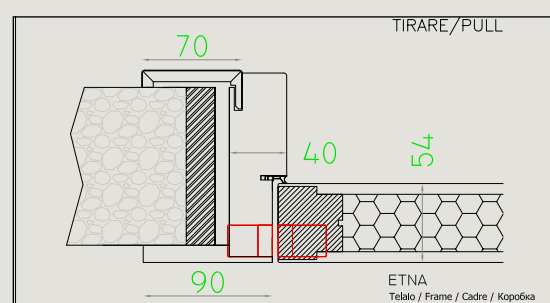
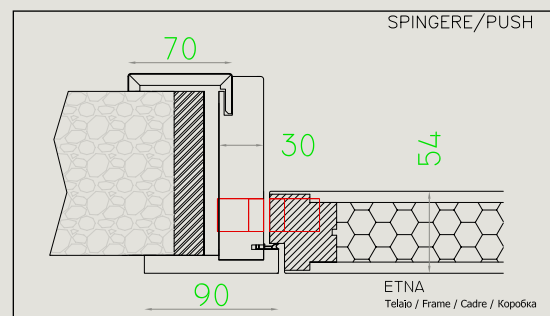

Luce passaggio Light opening Mesure de passage Чистый просвет по проходу	Misura esterno telaio External frame Encombrement du cadre По внешней части коробки	Vano utile - Misura interno Controtelaio Wall opening or Internal sub-frame Passage utile-Intérieur du precadre Полезный проем-По внутренней части накладной коробки
X	A=X+80mm	B=X+100mm
Y	C=Y+40mm	D=Y+50mm

RASOMURO 1

Quota pavimento finito
Finished floor surface
Sol fini
Ковенный пол

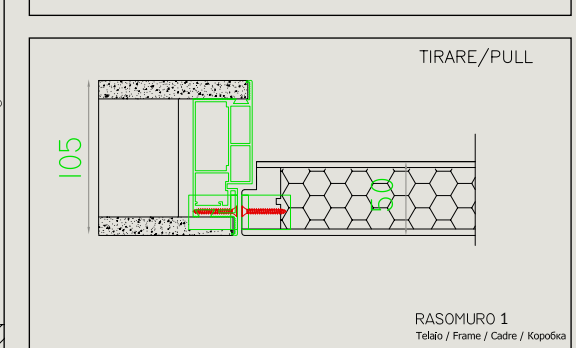
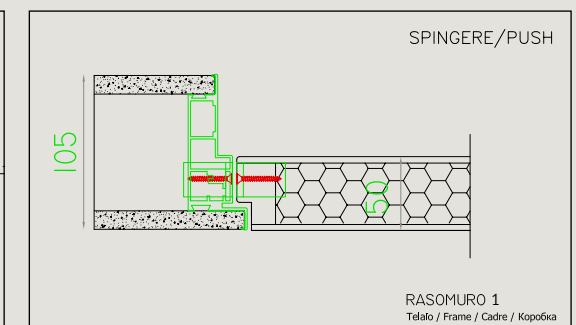

Luce passaggio Light opening Mesure de passage Чистый просвет по проходу	Misura esterno telaio External frame Encombrement du cadre По внешней части коробки	Vano utile - Misura interno Controtelaio Wall opening or Internal sub-frame Passage utile-Intérieur du precadre Полезный проем-По внутренней части накладной коробки
X	A=X+80mm	B=X+100mm
Y	C=Y+40mm	D=Y+50mm

ATENA

Quota pavimento finito
Finished floor surface
Sol fini
Ковенный пол

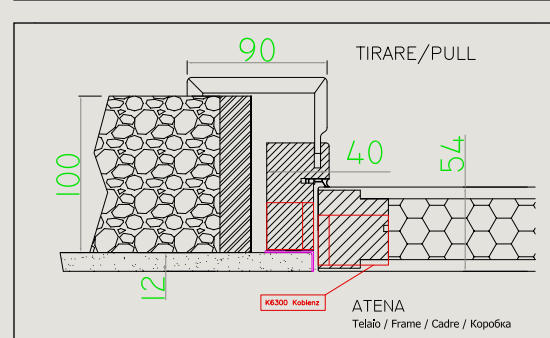
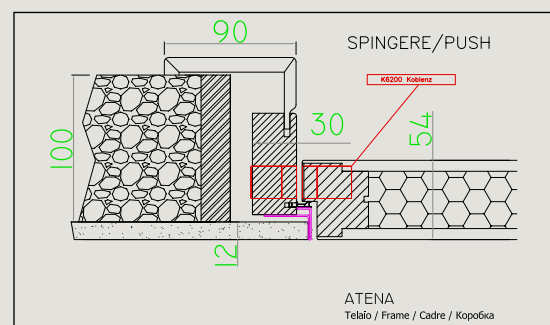

Luce passaggio Light opening Mesure de passage Чистый просвет по проходу	Misura esterno telaio External frame Encombrement du cadre По внешней части коробки	Vano utile - Misura interno Controtelaio Wall opening or Internal sub-frame Passage utile-Intérieur du precadre Полезный проем-По внутренней части накладной коробки
X	A=X+114mm	B=X+114mm
Y	C=Y+57mm	D=Y+57mm

RASOMURO 2

Quota pavimento finito
Finished floor surface
Sol fini
Ковенный пол

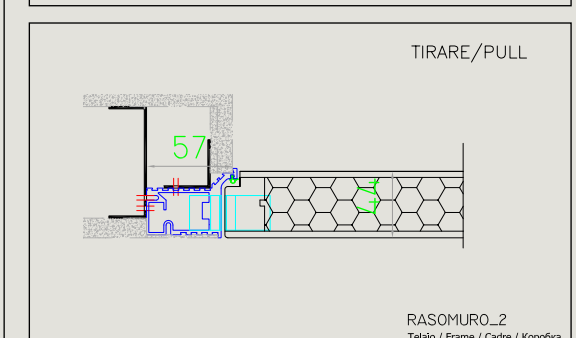
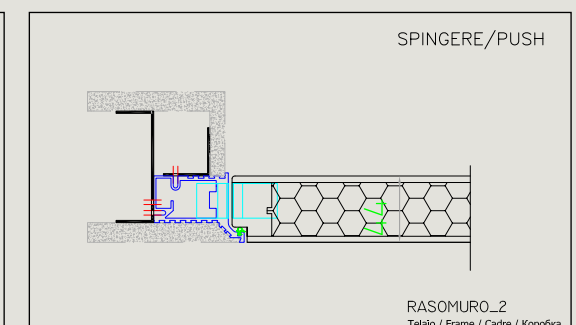

Luce passaggio Light opening Mesure de passage Чистый пролет по проходу	Misura pannello Panel size Dimension vantail РАЗМЕР ДВЕРНОГО ПОЛОТНА	Ingombro complessivo Overall size Encombrement hors tout ОБЩИЙ ГАБАРИТ
X	$A=X+80\text{mm}$	$B=2X+100\text{mm}$ (+40mm per montaggio pannello)
Y	$C=Y+150\text{mm}$	$D=Y+160\text{mm}$

ICARO (LEGNO/WOOD)
Scorrevole esterno
External sliding
Porte coulissante en applique
Дверь, откатная по стене

Quota pavimento finito
Finished floor surface
Sol fini
Конечный пол

ICARO (LEGNO/WOOD)
Scorrevole esterno
External sliding
Porte coulissante en applique
Дверь, откатная по стене

Luce passaggio Light opening Mesure de passage Чистый пролет по проходу	Misura esterno telaio External frame Encombrement du cadre По внешней части коробки	Vano utile - Misura Interno Controtelaio Wall opening or Internal sub-frame Passage utile-Intérieur du precadre Полезный проем-По внутренней части накладной коробки
X	$A=X+80\text{mm}$	$B=X+100\text{mm}$
Y	$C=Y+40\text{mm}$	$D=Y+50\text{mm}$

KRONOS

Quota pavimento finito
Finished floor surface
Sol fini
Конечный пол

KRONOS (LEGNO/WOOD)

Luce passaggio Light opening Mesure de passage Чистый пролет по проходу	Misura pannello Panel size Dimension vantail РАЗМЕР ДВЕРНОГО ПОЛОТНА	Ingombro complessivo Overall size Encombrement hors tout ОБЩИЙ ГАБАРИТ
X	$A=X+100\text{mm}$	$B=A+X$
Y	$C=Y+140\text{mm}$	$D=Y+150\text{mm}$

EGEONE

Quota pavimento finito
Finished floor surface
Sol fini
Конечный пол

EGEONE (LEGNO/WOOD)
Scorrevole esterno
External sliding
Porte coulissante en applique
Дверь, откатная по стене

Luce passaggio Light opening Mesure de passage Чистый пролет по проходу	Misura esterno telaio External frame Encombrement du cadre По внешней части коробки	Vano utile - Misura interno Controtelaio Wall opening or Internal sub-frame Passage utile-Intérieur du precadre Полезный проем-По внутренней части накладной коробки
X	$A=X+144\text{mm}$	$B=X+164\text{mm}$
Y	$C=Y+50\text{mm}$	$D=Y+60\text{mm}$

ROTOTRASLANTE

Quota pavimento finito
Finished floor surface
Sol fini
Конечный пол

ROTOTRASLANTE

Luce passaggio Light opening Mesure de passage Чистый пролет по проходу	Misura pannello Panel size Dimension vantail РАЗМЕР ДВЕРНОГО ПОЛОТНА	Ingombro complessivo Overall size Encombrement hors tout ОБЩИЙ ГАБАРИТ
X	$A=X+80\text{mm}$	$B=2X+100\text{mm}$ (+40mm per montaggio pannello)
Y	$C=Y+170\text{mm}$	$D=Y+180\text{mm}$

VENUS (VETRO/GLASS)
Scorrevole esterno
External sliding
Porte coulissante en applique
Дверь, откатная по стене

Quota pavimento finito
Finished floor surface
Sol fini
Конечный пол

VENUS (VETRO/GLASS)
Scorrevole esterno
External sliding
Porte coulissante en applique
Дверь, откатная по стене

Luce passaggio Light opening Mesure de passage Чистый пролет по проходу	Misura esterno telaio External frame Encombrement du cadre По внешней части коробки	Vano utile - Misura Interno Controtelaio Wall opening or Internal sub-frame Passage utile-Intérieur du precadre Полезный проем-По внутренней части накладной коробки
X		
Y	$C=Y+55\text{mm}$	

SYMPOSIUM

Quota pavimento finito
Finished floor surface
Sol fini
Конечный пол

SYMPOSIUM

SYMPOSIUM

MIMESI

Disegni tecnici / Technical drawings / Shémas techniques / Технические рисунки

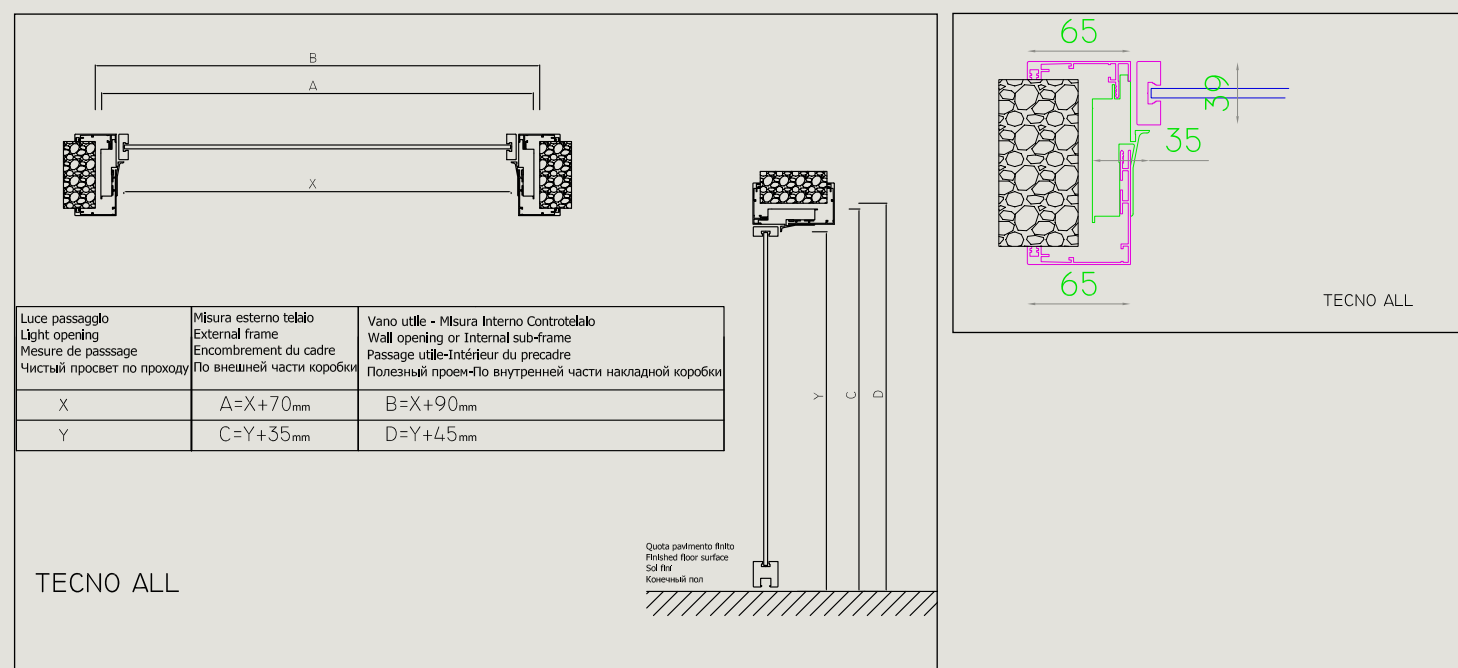

GENESI

Disegni tecnici / Technical drawings / Shémas techniques / Технические рисунки

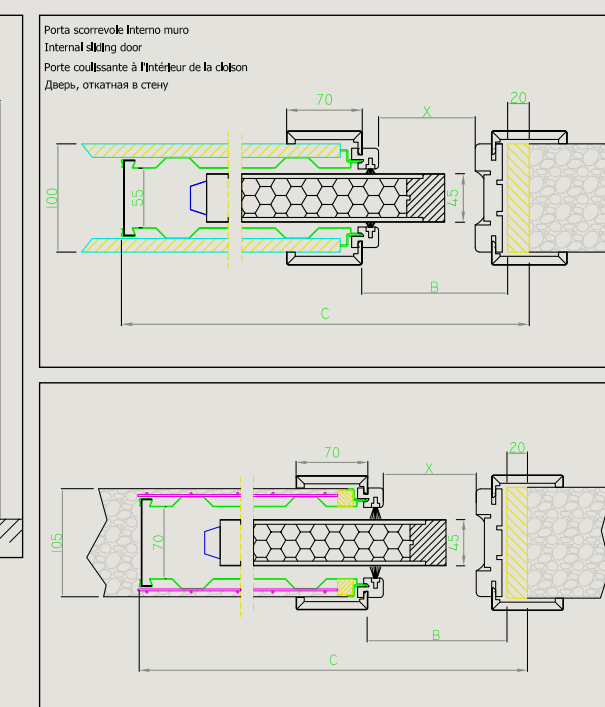
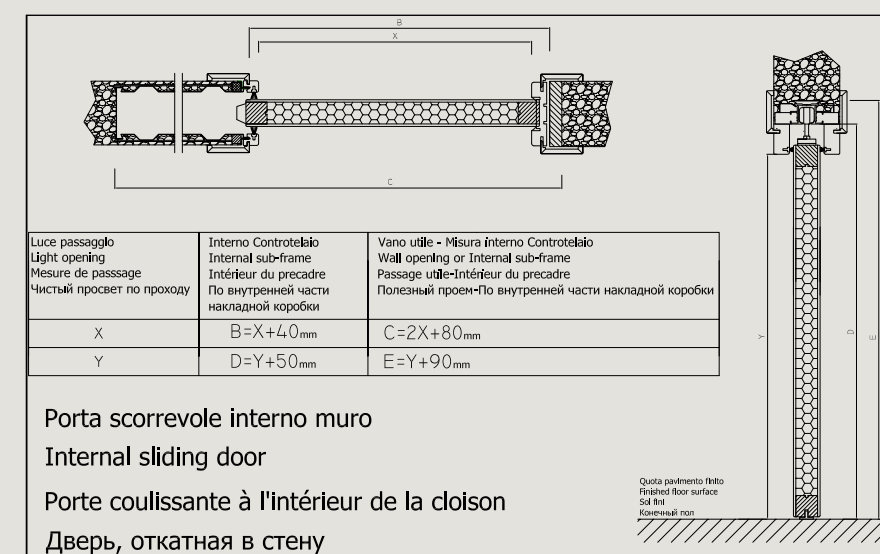
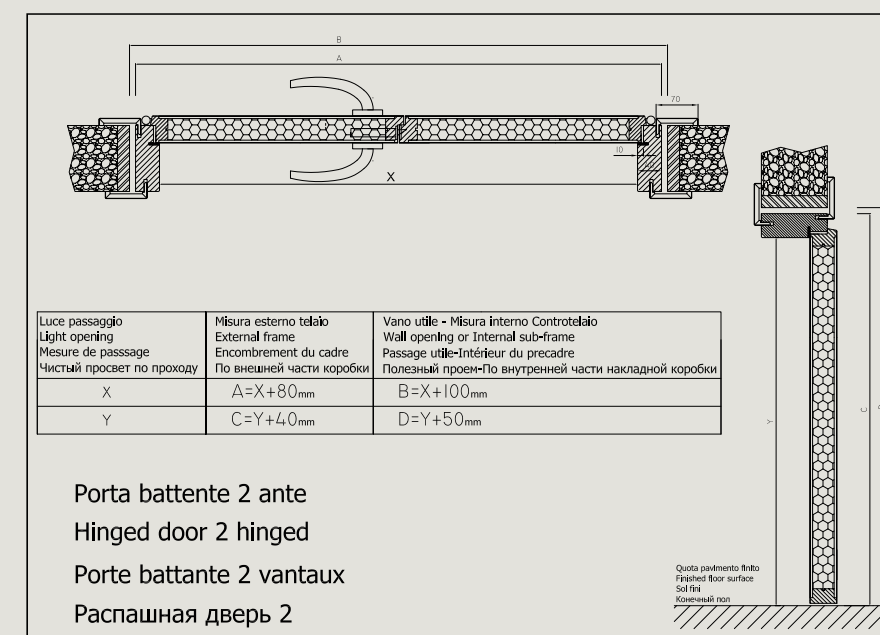
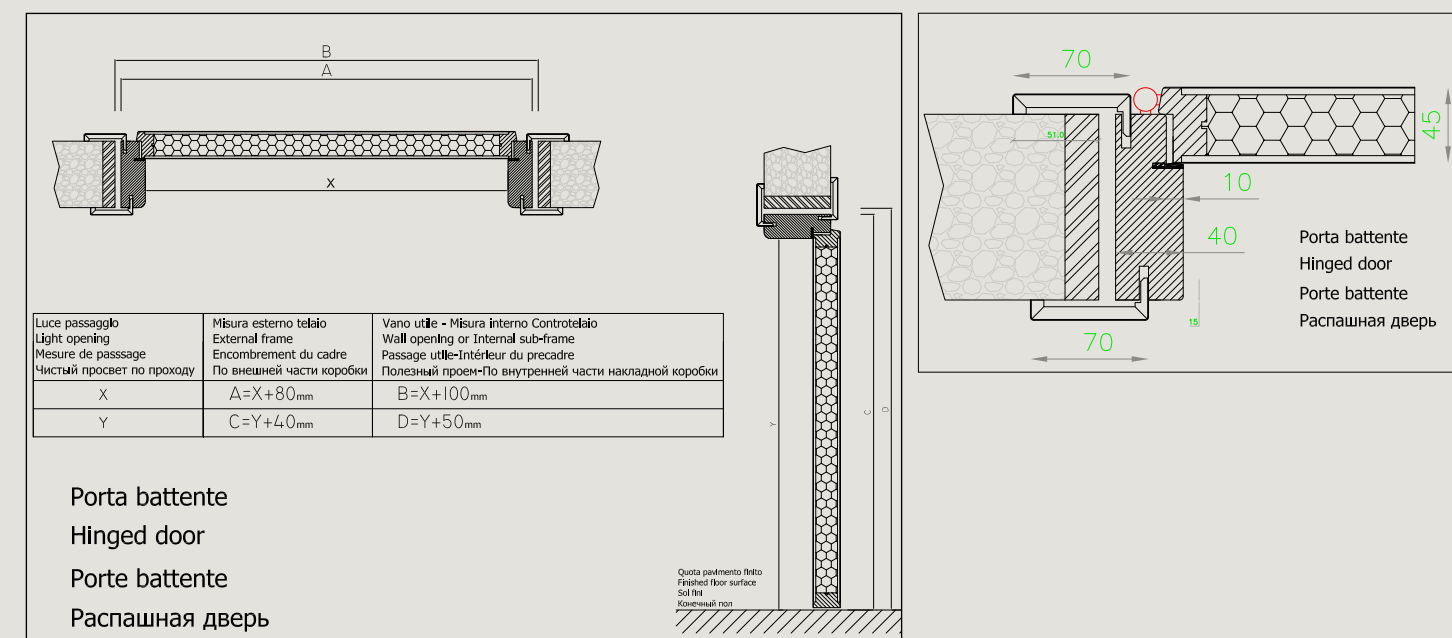

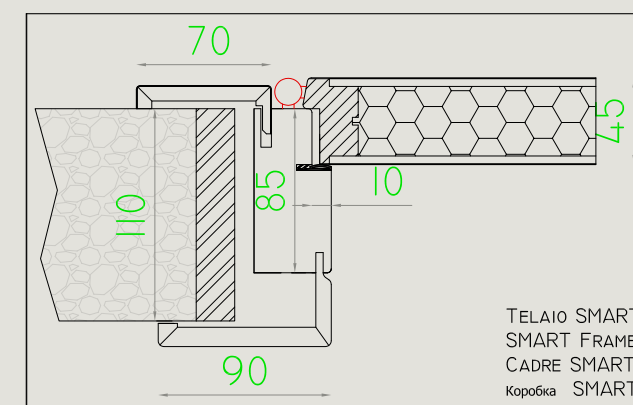
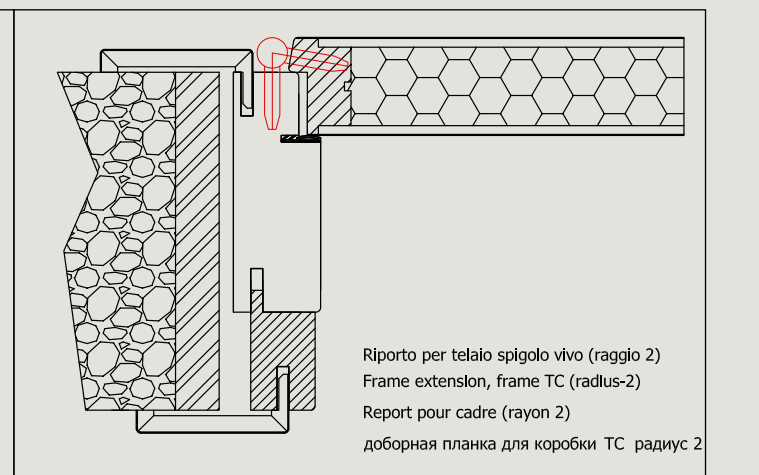
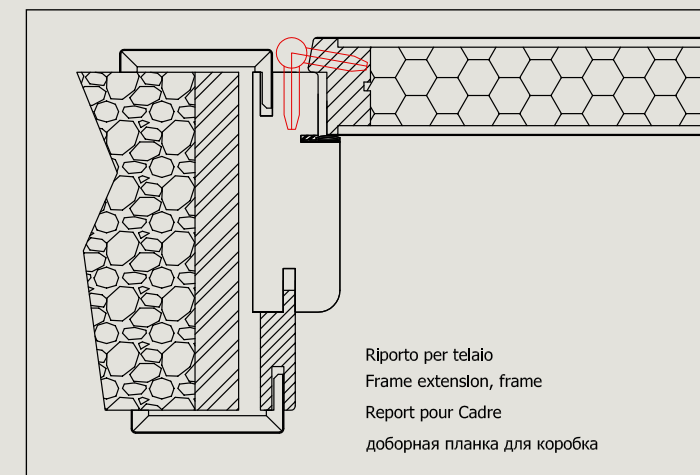
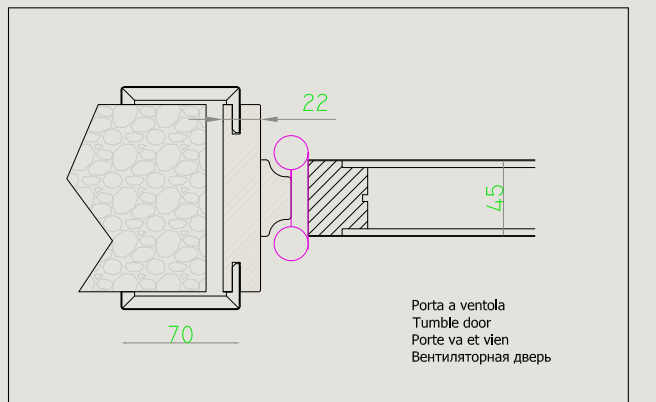
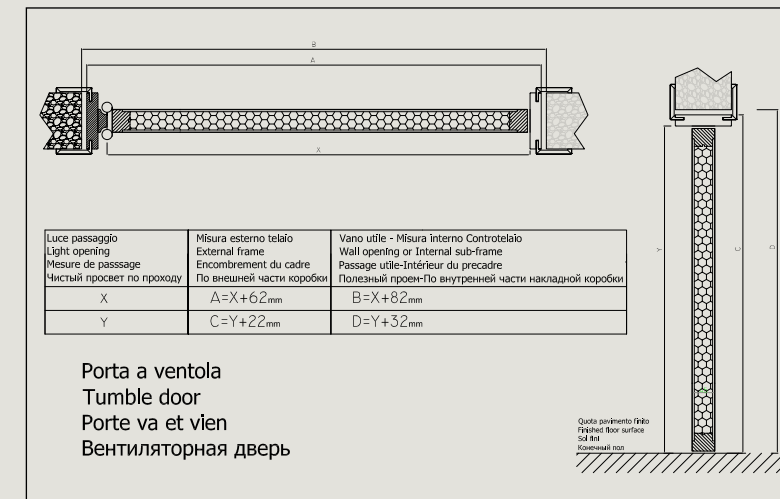
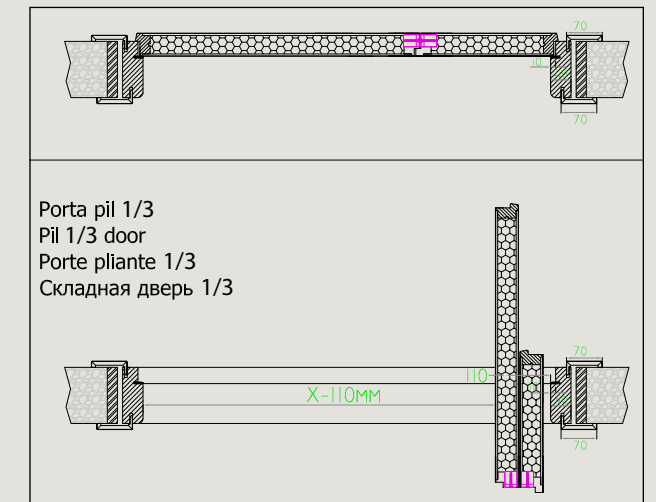
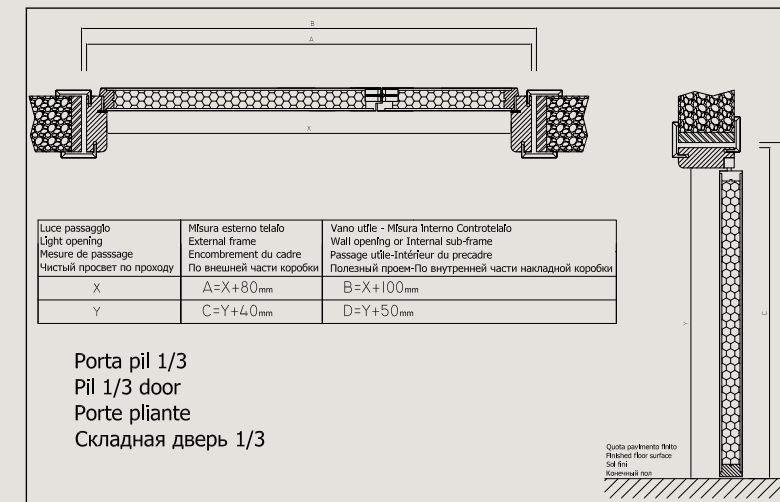
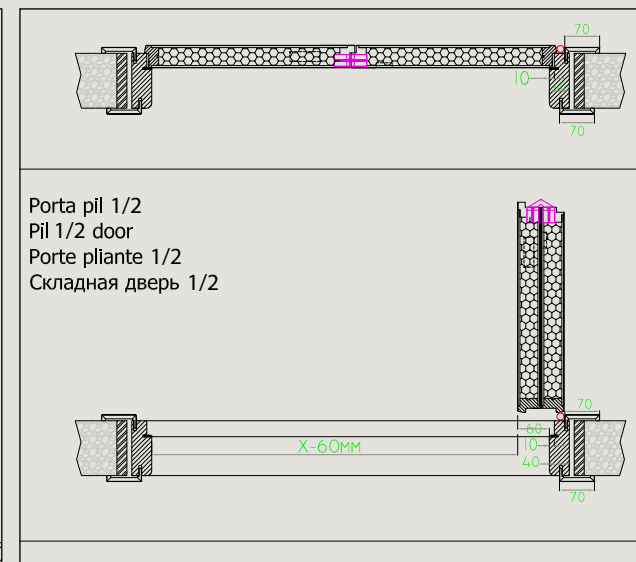
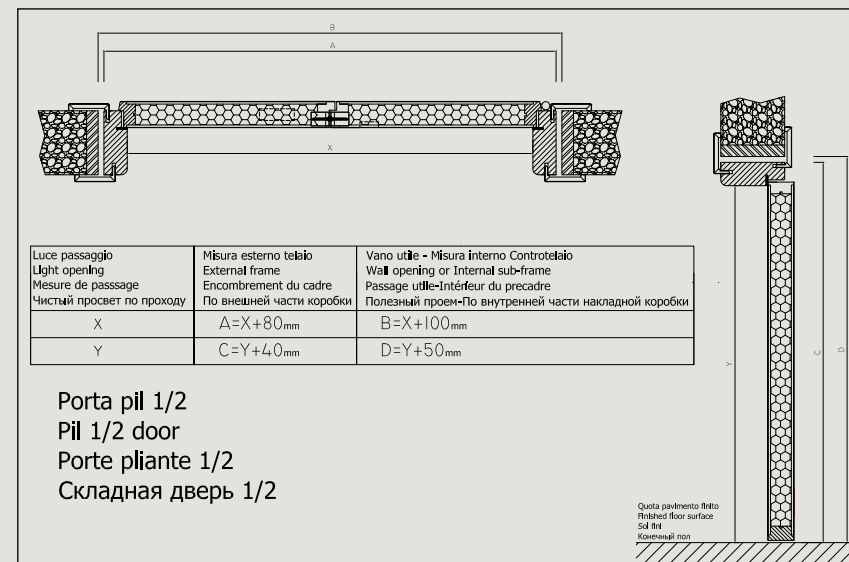
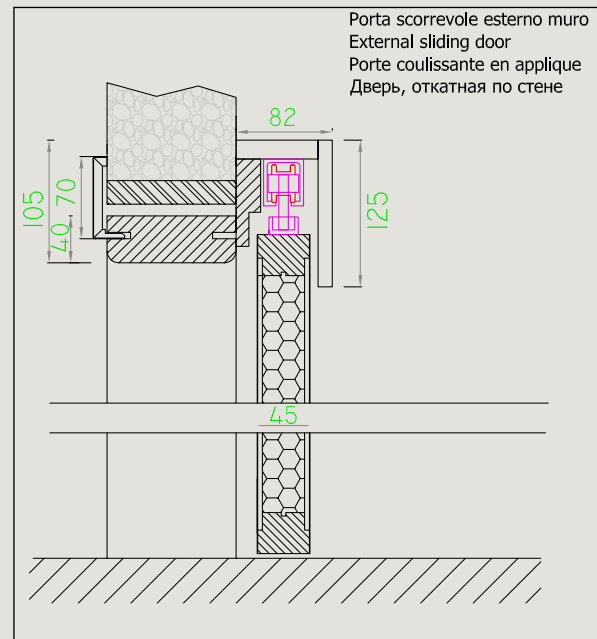
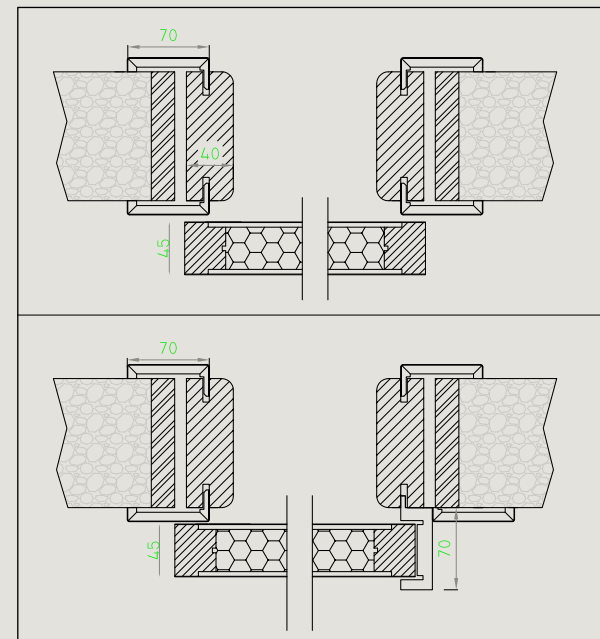
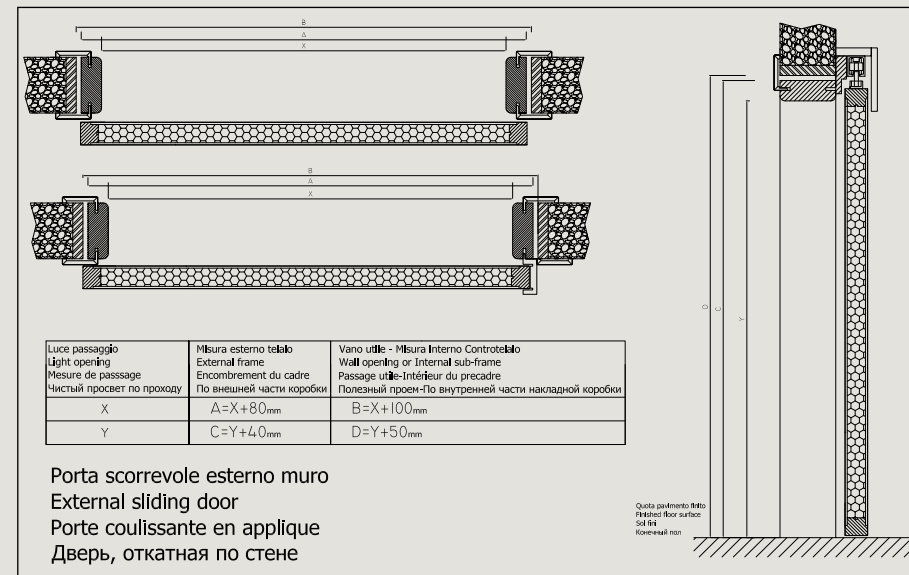



Cerniera a bilico registrabile
Adjustable pivot hinges



Telaio Compact
Frame Compact



Telaio Elegance
Frame Elegance



Telaio Quadrus
Frame Quadrus



Serratura magnetica
Magnetic lock



Cerniere a scomparsa
Concealed hinges

Laccato opaco / Matt lacquered



Bianco Pietrelli Panna Pietrelli 671 Avorio Pietrelli 242 Grigio Pietrelli 39 Savana Pietrelli

Laccato lucido spazzolato / Polished glossy lacquered

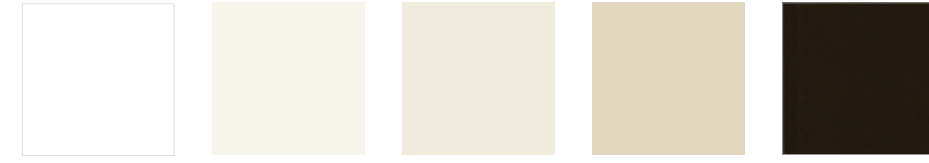

Bianco Pietrelli Panna Pietrelli 671 Avorio Pietrelli 242 Savana Pietrelli Moka Pietrelli

Ral chiari opachi / Matt Ral

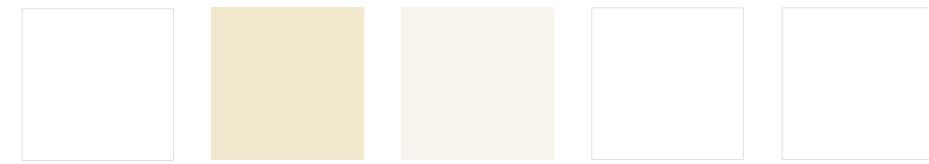

Bianco perla 1013 Avorio chiaro 1015 Bianco crema 9001 Bianco puro 9010 Bianco traffico 9016

Ral scuri opachi / Matt Ral



Rosso vino 3005 Amaranzo 3007 Rosso traffico 3020 Grigio umbro 7022 Grigio agata 7058 Marrone cioccolato 8017 Nero profondo 9005

Colori essenze / Wood



Rovere sbiancato Wengé Palissandro Rovere grigio Rovere moro

Termostrutturati / Thermo-structured

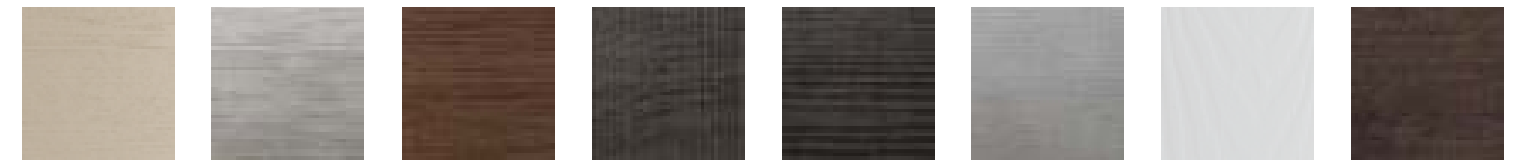

Poro aperto laccato Millerighe white Millerighe brown Dark lady Palude oak Silver Yosemite frassino laccato Bronze

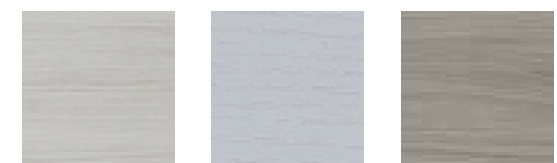

Rovere sabbia Rovere poro aperto Rovere grigio

Le tecniche di stampa non riproducono fedelmente le tonalità di colore che pertanto vanno considerate puramente indicative.
Be aware that these images may not reproduce the exact colours of our final products

Ad esclusione della versione impiallacciata, telaio e coprifili vengono sempre laccati in finitura testurizzata antigraffio.
Apart from the veneered doors, all other doors come with lacquered frame and frame-mouldings (anti-scratch lacquering)



Telaio TC raggio 2
Frame TC radius 2



Fregio '500
Fregio '500



Composto Classico
Composto Classico



Telaio Scalare
Telaio Scalare



Telaio scorrevole
Sliding frame



Cerniere Anuba
Hinges Anuba



Serratura Patent
Patent lock

Laccato opaco / Matt lacquered

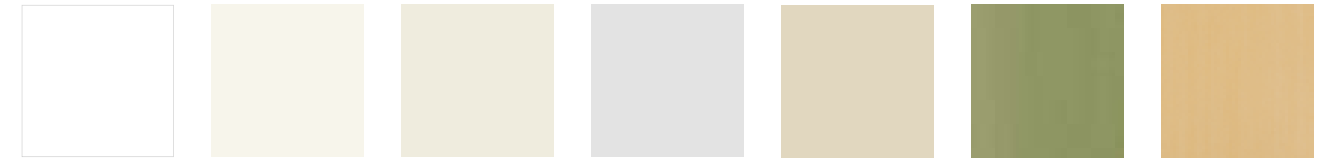

Bianco Pietrelli Panna Pietrelli 671 Avorio Pietrelli 242 Grigio Pietrelli 39 Savana Pietrelli Verde anticato Avorio anticato

Ral chiari opachi / Matt Ral

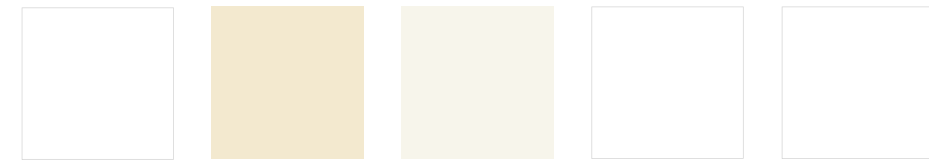

Bianco perla 1013 Avorio chiaro 1015 Bianco crema 9001 Bianco puro 9010 Bianco traffico 9016

Ral scuri opachi / Matt Ral



Rosso vino 3005 Amaranto 3007 Rosso traffico 3020 Grigio umbro 7022 Grigio agata 7038 Marrone cioccolato 8017 Nero profondo 9005

Colori essenze / Wood

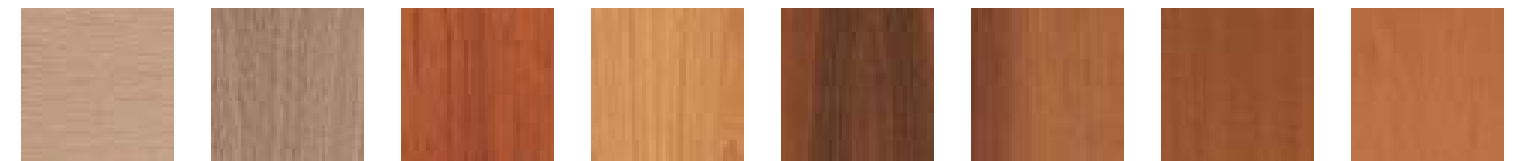

Rovere sbiancato Rovere naturale Ciliegio Noce nazionale biondo Noce nazionale bicolore Noce Tanganica naturale Noce Tanganica tinto medio Noce Tanganica tinto ciliegio

Laminati / Laminates



Bianco Grigio Sabbia

Laminati / Laminates



Rovere sbiancato Wengé

Le tecniche di stampa non riproducono fedelmente le tonalità di colore che pertanto vanno considerate puramente indicative.
Be aware that these images may not reproduce the exact colours of our final products

Ad esclusione della versione impiallacciata, telaio e coprifili vengono sempre laccati in finitura testurizzata antigraffio.
Apart from the veneered doors, all other doors come with lacquered frame and frame-mouldings (anti-scratch lacquering)

MIMESI / GENESI

Maniglie / Handle / Garniture / Ручка

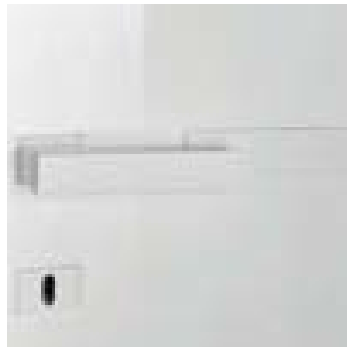

Dali
Laccato opaco
Matt lacquered



Dali
Cromato opaco
Matt chrome



Picasso
Laccato opaco
Matt lacquered



Picasso
Cromato opaco
Matt chrome



City
Acciaio inox
Stainless steel



York
Cromo satinato
Matt chrome



Brixia
Alluminio satinato
Matt aluminium

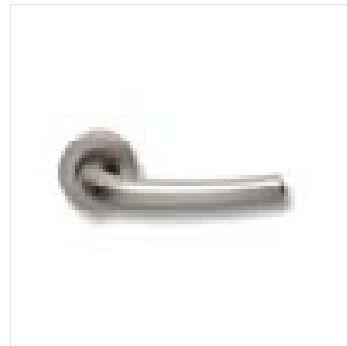

Milena
Cromo satinato
Matt chrome

Versi di apertura / Opening directions / Sens d'ouverture / Открывания

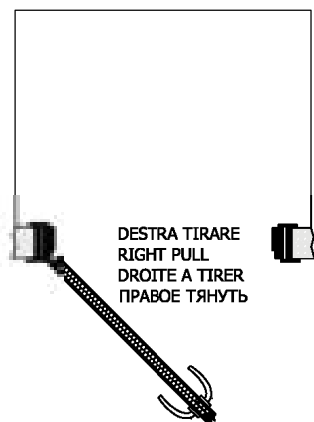



Fondata nel 1960 da Guido e Leandro Pietrelli, F.lli Pietrelli srl, produttrice di porte in legno per interni è oggi una realtà industriale che non perde la propria vocazione artigianale. Guidata dalla seconda generazione della famiglia, presente in azienda con i figli Roberto, Stefania, Lucia e Davide è una delle più importanti realtà produttive del territorio e impiega circa 50 persone, sviluppando una produzione interamente made in Italy ma con una forte vocazione internazionale.

L'azienda è riuscita a conquistarsi la sua nicchia di mercato con una strategia di gestione delle attività e dei processi di lavorazione volta ad ottimizzare la capacità di risposta alle esigenze del cliente.

La filosofia aziendale è infatti produrre per il cliente e non per il mercato. Ciò si espleta attraverso una gamma di prodotti vastissima e personalizzabile, impianti di produzione d'avanguardia, manodopera altamente specializzata, e un team dinamico che considera la collaborazione il suo principale punto di forza.

Founded in 1960 by Guido and Leandro Pietrelli, F.lli Pietrelli srl, a manufacturer of interior wooden doors, today is an industrial reality that don't forget its craft vocation. Guided by the second generation of the family with his sons Davide, Lucia, Roberto and Stefania, is one of the most important productive realities of the territory and employs about 50 people, developing a production entirely 100% Made in Italy but with a strong international vocation.

The company has succeeded in gaining its market niche with a strategy of managing activities and processes to optimize the ability to reply to customer enquiries.

Business philosophy is in fact is "produce for the customer and not for the market". This is accomplished through a wide and customized range of products, technological machineries, highly specialized manpower and a dynamic team that considers collaboration as its main strength.

Constituée dans le 1960 par Guido et Leandro Pietrelli, F.lli Pietrelli srl, fabricant de portes intérieures en bois, est aujourd'hui une réalité industrielle qui ne perd pas sa vocation artisanale. Guidé par la deuxième génération de la famille, les fils Davide, Lucia, Roberto et Stefania, est l'une des réalités productives les plus importantes du territoire qui emploie environ 50 personnes, développant une production entièrement réalisée en Italie, avec une forte vocation internationale aussi.

La société est réussi s'emplacer une niche du marché avec une stratégie de gestion d'activités et de proces de traitement afin d'optimiser la capacité à répondre aux besoins des clients.

La philosophie d'entreprise est de produire pour le client et non pour le marché. Cela s'effectue grâce à une gamme vaste et personnalisable de produits, des installations en production ultramodernes, une main-d'œuvre hautement spécialisée et une équipe dynamique qui considère la collaboration comme sa principale force.

Основанная в 1960 году Гвидо и Леандро Пиетрелли, фабрика F.lli Pietrelli srl, производитель межкомнатных двери из дерева, сегодня является индустриальной реальностью и не теряет своего ремесленного призвания. Компания управляется вторым поколением семьи, представленным Давидом, Люцией, Роберто и Стефанией, является одним из самых важных региональных производителей, имеет около 50 человек в штате и работает по принципу 100% Made in Italy, получив при этом несомненное международное признание.

Предприятию удалось завоевать собственную нишу на рынке посредством гибкой стратегии управления производственными процессами, направленной на повышение способности реагировать на потребности клиентов. Философия компании - на самом деле производить для клиента, а не для рынка.

Что достигается благодаря обширной и персонализируемой гамме продуктов, новейшим производственным установкам, высококвалифицированному персоналу и динамичной команде, которая считает сотрудничество своей главной силой.



Qualità dei materiali, ricercatezza dei dettagli, standard prestazionali elevati in qualsiasi contesto: le soluzioni di Pietrelli Porte soddisfano le esigenze estetiche e funzionali in qualsiasi contesto per rispondere alle specifiche esigenze del progetto, sia che si tratti di edifici residenziali sia per interventi contract.

Estetica e prestazioni sono un binomio indispensabile per affrontare progetti di pregio. Senza dimenticare l'ambiente: Pietrelli Porte nel 2011 ha installato un impianto fotovoltaico di proprietà parzialmente integrato sopra i tetti dei suoi 2 stabilimenti di 15.000 mq complessivi per la generazione di circa 450 KW all'anno, potenza sufficiente a coprire il proprio fabbisogno industriale. Sempre nell'ottica di fare impresa nel rispetto dell'ambiente, l'azienda si è anche certificata FSC, per permettere ai propri clienti di identificare una gestione corretta e responsabile delle foreste da cui derivano il legno e i prodotti legnosi impiegati nella produzione aziendale.

Tutti i prodotti della Linea Hotel sono personalizzabili per colore, dimensione e finitura e sono disponibili nelle versioni ignifuga fino a 120 minuti e insonorizzata fino a 42 dB, certificate nel rispetto della vigente normativa europea UNI EN 1634 e su richiesta, con certificazione FSC - LEED ZERO.

FSC rappresenta un sistema di certificazione forestale riconosciuto a livello internazionale. La certificazione ha come scopo la corretta gestione forestale e la tracciabilità dei prodotti derivati. Il logo di FSC garantisce che il prodotto è stato realizzato con materie prime derivanti da foreste correttamente gestite secondo i principi dei due principali standard: gestione forestale e catena di custodia.

Quality of materials, refinement of detail, high performance standards in any context: Pietrelli Porte solution meets the aesthetic and functional requirements for residential and contractual projects.

Aesthetics and performance are an indispensable combination of valuable projects without forgetting the environment: in 2011, an integrated photovoltaic plant was installed on the roof of its 15,000 square-meters; a facility for generating around 450 KW per year, enough power to cover their industrial needs. Always in the business environment, the company has also been certified by FSC to allow its customers to identify the proper and responsible management of the woods from which these products are used in the company's production.

All Hotel Collection products are customizable in color, size and finishing and are available in fireproof versions from 30 up to 120 minutes with soundproof reduction of 34 up to 44 dB, certified according to the current European UNI EN 1634 standard norms and on request, with certification FSC - LEED ZERO.

FSC represents an internationally recognized forest certification system. The aim of the certification is to ensure proper forest management and traceability of wooden products. The FSC logo ensures that the product is made from raw materials derived from forests properly managed according to the principles of the two main standards: forestry management and chain of custody.

Qualité des matériaux, raffinement des détails, normes de haute performance dans tous les contextes: les propositions de Pietrelli Porte répondent aux exigences esthétiques et techniques pour le client qui demande un projet spécifique, soit un hôtelier, soit résidentiel, soit contractuel.

L'esthétique et la performance sont une combinaison indispensable de projets précieux sans oublier l'environnement: en 2011, une installation photovoltaïque intégrée a été installée sur les toits de ses 2 installations de 15 000 mètres carrés pour générer environ 450 KW par an, assez de puissance pour couvrir leurs besoins industriels. Toujours dans l'environnement commercial, la société a également été certifiée par FSC certificate, pour permettre à ses clients d'identifier la gestion responsable des forêts dont les produits du bois sont utilisés dans la production de l'entreprise.

Tous les produits Hotel sont disponibles sur mesure, en couleur, en taille et en finition et sont disponibles en versions ignifuges de 30 à 120 minutes avec une réduction du bruit de 34 jusqu'à 44 dB, certifiée selon la norme européenne UNI EN 1634 et sur demande, avec certification FSC - LEED ZERO.

FSC représente un système de certification forestière internationalement reconnu. L'objectif de la certification est d'assurer une gestion adéquate de la forêt et la traçabilité des produits dérivés. Le logo FSC garantit que le produit est fabriqué à partir de matières premières dérivées de forêts correctement gérées selon les principes des deux principales normes: gestion forestière et chaîne de protection.

Qualità dei materiali, ricercatezza dei dettagli, standard prestazionali elevati in qualsiasi contesto: le soluzioni di Pietrelli Porte soddisfano le esigenze estetiche e funzionali in qualsiasi contesto per rispondere alle specifiche esigenze del progetto, sia che si tratti di edifici residenziali sia per interventi contract.

Estetica e prestazioni sono un binomio indispensabile per affrontare progetti di pregio. Senza dimenticare l'ambiente: Pietrelli Porte nel 2011 ha installato un impianto fotovoltaico di proprietà parzialmente integrato sopra i tetti dei suoi 2 stabilimenti di 15.000 mq complessivi per la generazione di circa 450 KW all'anno, potenza sufficiente a coprire il proprio fabbisogno industriale. Sempre nell'ottica di fare impresa nel rispetto dell'ambiente, l'azienda si è anche certificata FSC, per permettere ai propri clienti di identificare una gestione corretta e responsabile delle foreste da cui derivano il legno e i prodotti legnosi impiegati nella produzione aziendale.

Tutti i prodotti della Linea Hotel sono personalizzabili per colore, dimensione e finitura e sono disponibili nelle versioni ignifuga fino a 120 minuti e insonorizzata fino a 42 dB, certificate nel rispetto della vigente normativa europea UNI EN 1634 e su richiesta, con certificazione FSC - LEED ZERO.

FSC rappresenta un sistema di certificazione forestale riconosciuto a livello internazionale. La certificazione ha come scopo la corretta gestione forestale e la tracciabilità dei prodotti derivati. Il logo di FSC garantisce che il prodotto è stato realizzato con materie prime derivanti da foreste correttamente gestite secondo i principi dei due principali standard: gestione forestale e catena di custodia.



PIETRELLI

Grafica
Eikon

Fotografia
Simone Roscini
Er Photography

Stampa
Grapho5

